

9000 SERIES

API 682 SEALS

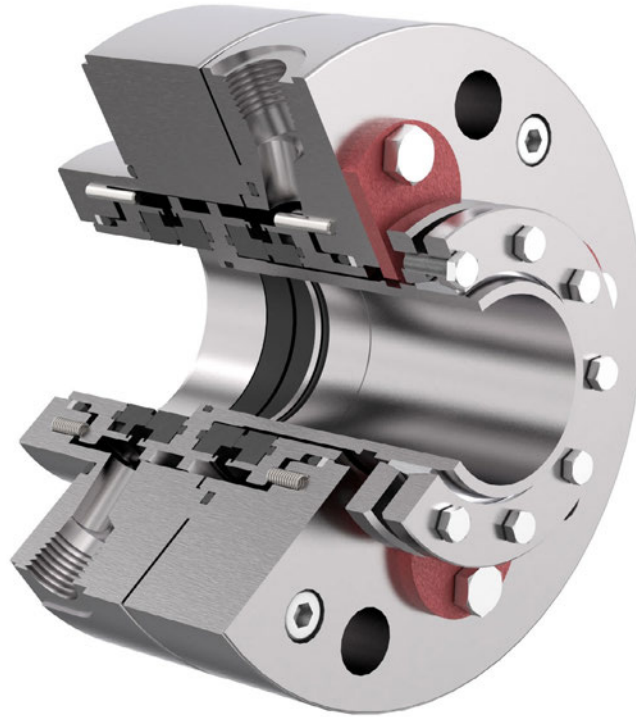

MECHANICAL SEALS FOR THE
OIL & GAS INDUSTRY

THOMSON API SEALS

A.R. Thomson Group Inc. (ARTGI) has a complete range of single and dual cartridge mechanical seals for the most challenging API applications found in the Canadian heavy crude market. Our designs give optimal performance in all areas of heavy oil and synthetic crude production.

Rotating or Stationary Flexible Element?

The Thomson 9000 series pusher seals are all stationary flexible element as standard.

API 682 4th Edition

Perpendicularity of the mating ring to the shaft axis is important for both stationary and rotating flexible element designs.

Perpendicularity for a rotating mating ring mounted on the sleeve (where a stationary flexible element is used) is controlled by the seal sleeve run out and perpendicularity of support surface on the sleeve. It is independent of the seal chamber face run out. An advantage of a stationary flexible element is that it will deflect to a fixed position to align with the rotating face.

Suspended Solids

Seals using a stationary flexible element with springs external to the process liquid are also a proven design in process fluids with high particulate concentrations

Stationary flexible elements are preferred in many oil and gas applications such as:

- High temperature pumps
- Multi-stage pumps
- Pump installations with high pipe strain
- High speed applications
- Shaft diameters above 4.25"

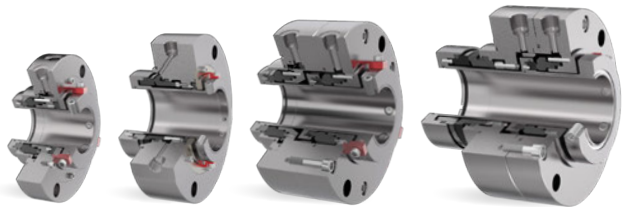

9100 Series

Single & Dual Cartridge Seals Flashing Hydrocarbon Service

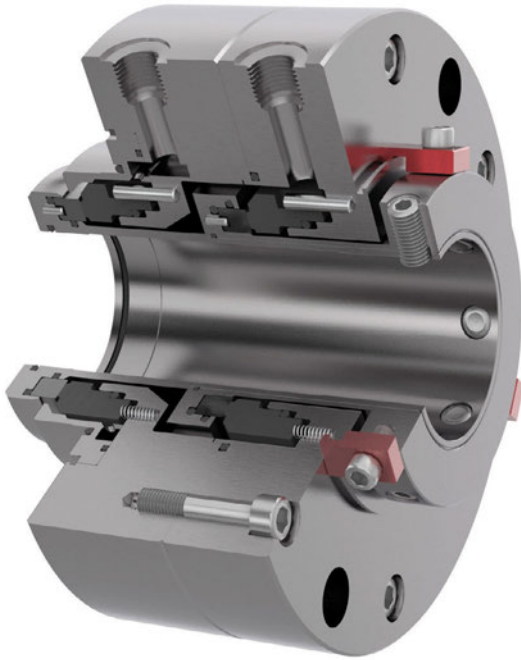

The Thomson 9100 (S/D) series features a unique face geometry designed to reduce the effect of face “coning” in applications involving low vapor pressures. The flush port configuration is specially designed to prevent voids at the seal faces which increases performance and reliability.

Features

- Robust faces resistant to deflection at high pressures and temperatures.
- Very low emission design.
- Low friction face geometry.
- Compact construction for easy retrofit to most pumps.
- Multi port flush.
- No spark carbon throttle bushing to restrict process flow to atmosphere.
- Self aligning design for greater fluid film stability.

Applications

- Clean, Low density high pressure hydrocarbons.
- Propane-butane, Ethanol, Acetone, ethylene hydrocarbons.
- Oil Refining.
- Chemical.
- Petrochemical.
- Operates with API 682 plan: 11, 12, 13, 21, 32 and 64. (9100S)
- Designed according to API 682 Type A, category 2 or 3, arrangement 1, configuration 1CW-FL (with floating carbon restriction bushing). (9100S)
- Operates with API 11/52, 11/53, 12/52, 12/53, 53a,b,c and 54 piping plans. (9100D)
- Designed according to API 682 Type A, category 2 or 3, arrangement 2CW-CW or 3CW-FB. (9100D)

Operating Range

All operating range information is dependent on media, materials of construction, and support systems used. Please contact A.R. Thomson mechanical seal services department for more information.

Temperature:

-40 to 176°F (-40 to -80°C)
 176 to 265°F (80 to 130°C)
 265 to 350°F (130 to 180°C)
 350 to 482°F (180 to 250°C)

Pressure Max:

510 psig (35 bar)
 450 psig (31 bar)
 400 psig (28 bar)
 320 psig (22 bar)



9200 Series

Single & Dual Cartridge Seals Moderate Slurries

The Thomson 9200 (S/D) series pusher seals are all stationary flexible element as standard. A stationary design intended for general and light slurry applications; the 9200 series is the work horse of the 9000 series range. The dual seal design offers a lower profile than legacy API seals allowing for retrofit to dual seals in older API610 series pumps.

Features

- Robust faces resistant to abrasives.
- Monolithic faces resist deflection at high pressures and temperatures.
- Flush and quench/drain ports.
- Self-aligning face design as standard.
- Springs separated from process media.

Applications

- Crude oil.
- Hydrocarbons with contaminants/abrasives.
- Oil Refining.
- Petrochemical.
- Operates with API 11/61, 11/62, 12/61, 12/62, 13/61, 13/62, 64 and 65 piping plans. (9200S)
- Designed according to API 682 Type A, category 2 or 3, arrangement 1CW-FL. (9200S)
- Operates with API 11/52, 11/53a, 12/52, 12/53a, 13/53a, 53b, 53c and 54 piping plans. (9200D)
- Designed according to API 682 Type A, category 2 or 3, arrangement 2CW-CW or 3CW-FB. (9200D)

Operating Range

All operating range information is dependent on media, materials of construction, and support systems used. Please contact A.R. Thomson mechanical seal services department for more information.

Temperature:

360°F (180°C)

Pressure Max:

600 psig (40 bar)

Speed, Max (9200D):

4000 fpm (20 m/s)



9300

Single Bellows Cartridge Seal High Temperature

The Thomson 9300 is metal bellows seal for high temperatures and eliminates the need for a dynamic o-ring which can limit seal life. The 9300 can be supplied with all-Grafoil® secondary seals for extreme temperatures to 800°F/425°C.

Features

- Low emission.
- Quench/drain, flush ports.
- Compact construction for easy retrofit to smaller pumps.
- No spark carbon throttle bushing to restrict process flow to atmosphere.
- Cartridge design for quick and easy installation.
- Full Grafoil® design available.

Applications

- Hydrocarbons.
- Oil Refining.
- Petrochemical.
- Process side: Operates with API plan 11, 12, 13, 23, 31, 32.
- Atmospheric Side: Operates with API plan 61, 62, 65.
- Designed according to API 682 Type B, category 1 or 2 arrangement 1 configuration 1CW-FL.

Operating Range

All operating range information is dependent on media, materials of construction, and support systems used. Please contact A.R. Thomson mechanical seal services department for more information.

Temperature:

400°F (200°C)

Pressure Max:

290 psig (20 bar)

Speed, Max:

4000 fpm (20 m/s)

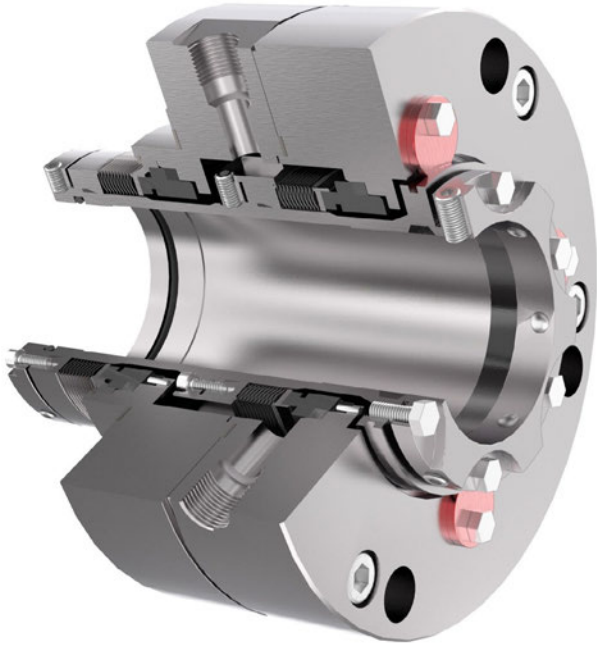

9400D

Dual Bellows Cartridge Seals High Temperature

Dual bellows cartridge seal with graphite gaskets for high temperature applications in the oil refining and petro-chemical industries to 800°F/425°C.

Features

- High temperature/ pressure capability.
- Design conforms to API Type B Category 2 or 3 arrangement 2 or 3 configuration 2CW-CW or 3CW-FB.
- Cartridge design for quick and easy installation.
- Full Grafoil® version available.

Applications

- Hot Hydrocarbons.
- Oil Refining.
- Petrochemical.
- Operates with API Flush plan 52, 53 or 54.

Operating Range

All operating range information is dependent on media, materials of construction, and support systems used. Please contact A.R. Thomson mechanical seal services department for more information.

Temperature:

750°F (400°C)

Pressure Max:

290 psig (20 bar)

Speed, Max:

5000 fpm (25 m/s)

9700 Series

Single & Dual Cartridge Seals High Pressure

The 9700 is designed to suit specialty applications such as primary charge, pipeline and boiler feed applications.

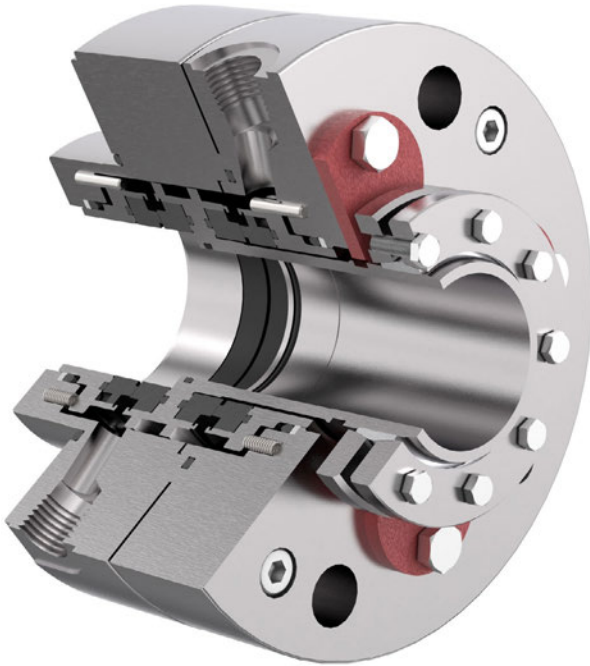

Features

- Pressure coning resistant faces.
- Monolithic design.
- High pressure drive design as standard.

Applications

- High-energy pumps found in charge pumps.
- Boiler feed.
- Pipelines.
- Oil and gas.
- Operates with API 11/61, 11/62, 12/61, 12/62, 13/61, 13/62, 64 and 65 piping plans. (9700S)
- Operates with API 11/52, 11/53a, 12/52, 12/53a, 13/53a, 53b, 53c and 54 piping plans. (9700D)
- Engineered sealing solution for services outside the normal scope of *API 682 4th Edition*.

Operating Range

All operating range information is dependent on media, materials of construction, and support systems used. Please contact A.R. Thomson mechanical seal services department for more information.

Temperature:

360°F (180°C)

Pressure Max:

1880 psig (130 bar)

Speed, Max:

5000 fpm (25 m/s)

Other Products

METALLIC GASKETS



Thomson CANFLEX® spiral wound, Kamprofile, high temperature, heat exchanger and ring joint gaskets. We manufacture gaskets from all common metals, exotic alloys and filler materials in all configurations for the most extreme applications.



FASTENERS

All thread studs – ASTM 193 Grade B7, B7M, B8, B8M, B16, ASTM A320 L7, L7M; heavy hex nuts – ASTM A194 Grade 2H, 2HM, 4, L7, L7M, 8 and 8M; Through hardened washers – ASTM F-436; custom coatings; specialty fabricated and machined studs; CANFLEX® approved thread lubricant.

SUPERLOK CANADA



Instrumentation Tube, Pipe, JIC and DIN Fittings. Instrumentation Ball, Bleed, Check, Double Block and Bleed, Needle, Plug, and Purge Relief Valves. Quick Connects and Filters. Flexible Metal Hose, Tubing and Accessories.



NON-METALLIC GASKETS

Thomson Performance Sealing (TSP) and gaskets fabricated from all types of sheet material including compressed, cork, cork/rubber blends, gasket types, Teflon™, Garlock®, Gore®, all rubber materials, Thomson Multipac and Flexible Graphite.



The A.R. Thomson Group Inc. was established in 1967 as a regional manufacturer & distributor of gaskets and other fluid containment products. With the rapid growth of oil and gas production, petrochemical, oil refining and pulp and paper industries, our manufacturing facilities expanded to meet increased demand for these products. Since 1967, we have developed our expertise and know-how to become the leader in solving fluid containment and control problems. No matter what your control or containment needs, we can help.