

# SLURRY SERVICE

TAC Slurry Seals are advanced, efficient, and environmentally sustainable sealing solutions for the most challenging and intricate slurry applications.

Slurry service can be among the most challenging of mechanical seal applications. As modern mining and mineral extraction processes develop to become more efficient and environmentally sustainable, so must the available sealing solutions to meet these new demands. The A.R. Thomson Group Inc. line of TAC Slurry seals offers everything from more traditional solutions to state-of-the-art designs and materials. All focused on improving MTBF, plant safety and protecting the environment.

## There are often many challenges in a slurry application. These include:

- Remote installation, either tailings or remote booster locations, makes monitoring mechanical seals difficult. Also, these locations may not have suitable quench water available.
- Local weather, with many such applications being outside seasonal weather, must be considered, often meaning that barrier fluid systems are impractical.
- Larger size pumps, lower speeds: Many modern slurry pump applications use much larger diameter pumps, reducing the pump components' abrasive wear. However, lower shaft speeds can reduce the effectiveness of pumping scrolls in dual slurry seals.
- Limited service windows for larger remote pumps. Servicing larger pumps is always costly, especially in difficult-to-reach locations.
- High solids concentrations. In addition to often not being suitable for a dual seal support system, high solids content media is typically unsuited for single seal use.

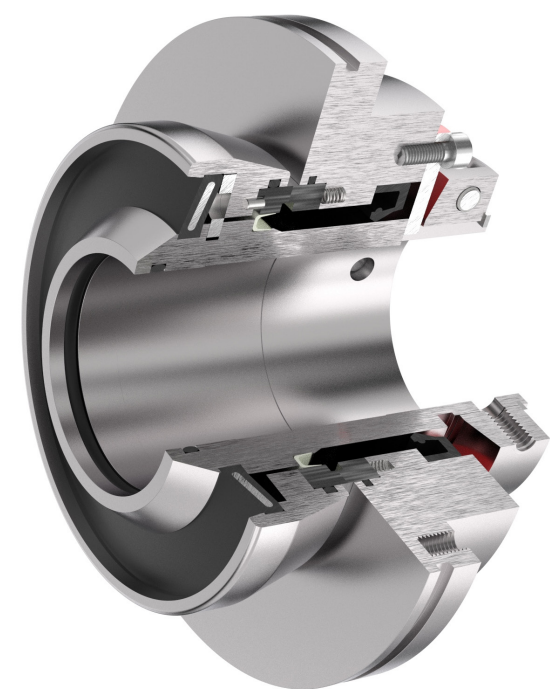

## Other Products



### METALLIC GASKETS

Thomson CANFLEX® spiral wound, Kamprofile, high temperature, heat exchanger and ring joint gaskets. We manufacture gaskets from all common metals, exotic alloys and filler materials in all configurations for the most extreme applications.



### SUPERLOK CANADA

Instrumentation Tube, Pipe, JIC and DIN Fittings. Instrumentation Ball, Bleed, Check, Double Block and Bleed, Needle, Plug, and Purge Relief Valves. Quick Connects and Filters. Flexible Metal Hose, Tubing and Accessories.



### FASTENERS

All thread studs – ASTM 193 Grade B7, B7M, B8, B8M, B16, ASTM A320 L7, L7M; heavy hex nuts – ASTM A194 Grade 2H, 2HM, 4, L7, L7M, 8 and 8M; Through hardened washers – ASTM F-436; custom coatings; specialty fabricated and machined studs; CANFLEX® approved thread lubricant.



### MECHANICAL SEALS

Advanced cartridge and component seals for pumps, mixers, compressors and other rotating equipment. Seal replacements for major brands such as John Crane, Flowserve, AES and more.



The A.R. Thomson Group Inc. was established in 1967 as a regional manufacturer & distributor of gaskets and other fluid containment products. With the rapid growth of oil and gas production, petrochemical, oil refining and pulp and paper industries, our manufacturing facilities expanded to meet increased demand for these products. Since 1967, we have developed our expertise and know-how to become the leader in solving fluid containment problems. No matter what your containment needs are, we can help.



## Mechanical Seals

# SLURRY SEALS

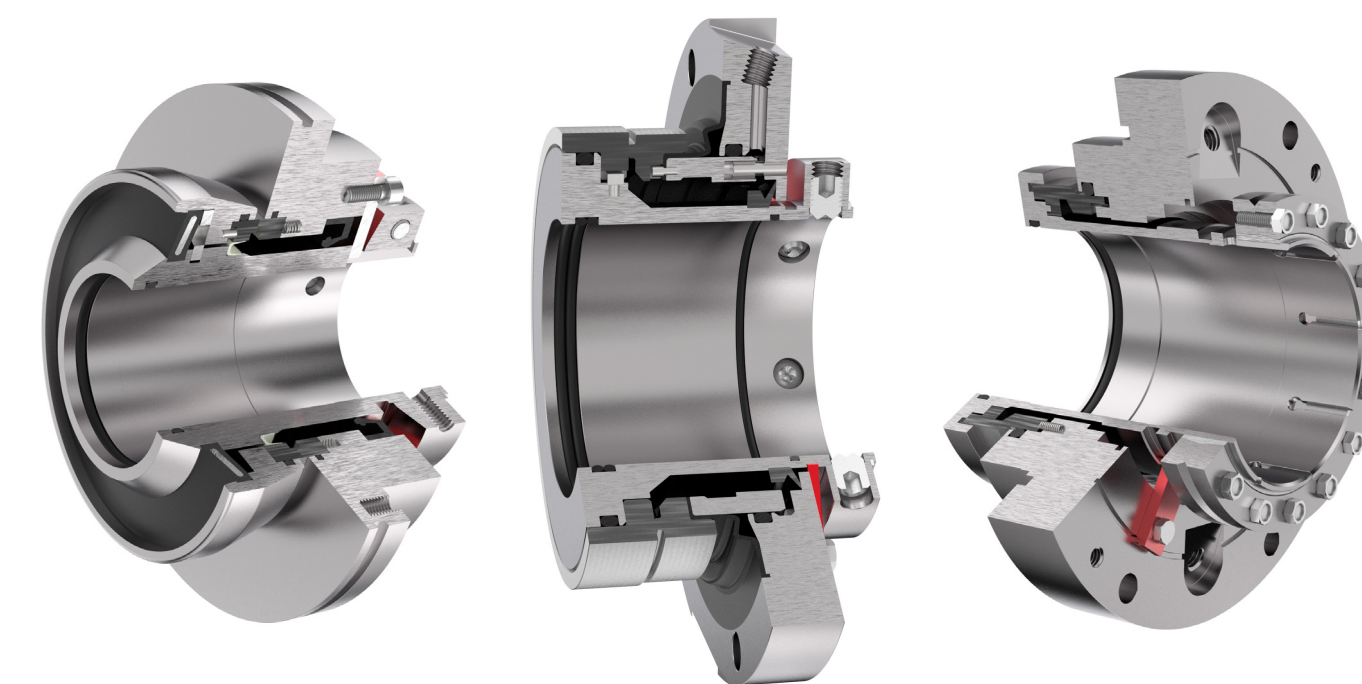

**FLUID CONTAINMENT  
SPECIALISTS SINCE 1967**

## TAC-600

Thomson TAC-600 heavy duty flush less slurry seal.

The Thomson TAC-600 a unique stationary sprung slurry seal design. Utilizing state of the art designs and materials that deliver a seal with excellent reliability.

### Features / Benefits

- Unique device to eliminate the possibility of face hang up.
- Suitable for smaller seal chambers than traditional slurry seals.
- Abrasion and corrosion resistant metallurgy matching the pump wetted parts.
- Pre-set cartridge simplifying installation.
- Self aligning face technology.
- Wrapped faces, reduces abrasive contact with metallurgy.

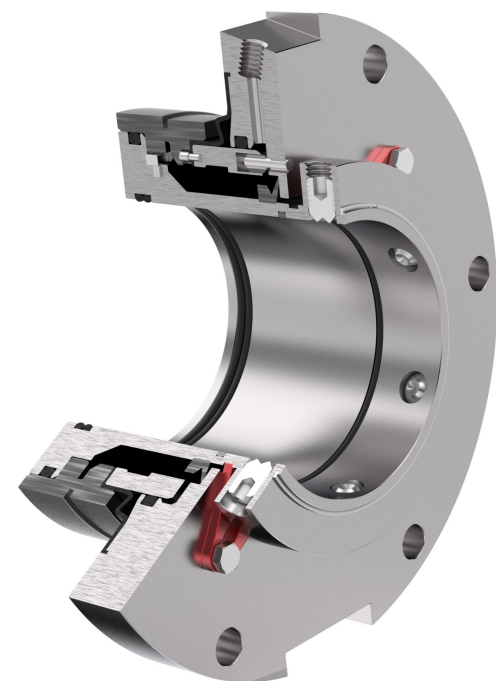

### Applications

- Heavy slurry applications.
- No flush available.
- Mining.
- Ore processing.
- Pulp and Paper.

### Specifications

All operating range information is dependent on media, materials of construction, and support systems used. Please contact A.R. Thomson mechanical seal services department for more information.

**Temperatures:** 300°F (150°C)  
**Max Pressure:** 300 PSI (20 bar)  
**Max Shaft Speed:** < 25m/s (< 4920 fpm)  
\*For pressures in excess of 150 psi (10 bar) consult A.R. Thomson.

### Standard Materials

**Wetted Parts\*:** CD4MCuN  
**Face Materials:** Silicone Carbide, Tungsten Carbide  
**Elastomers:** FKM, NBR, EPDM  
**Springs:** Hastelloy C

\*Other abrasion/corrosion-resistant materials available.

## TAC-620

Thomson TAC-620 heavy duty flush less slurry seal.

The Thomson TAC-620 is designed for demanding slurry service, capable of operating for extended periods without the need for a process diluting flush.

### Features / Benefits

- Balanced design, reducing face load in higher-pressure applications.
- Matched face OD at sealing dam. Eliminates potential for solids to build up at the faces during operation.
- Stationary sprung face design. Delivers more stable fluid film for longer seal life
- Damped rotary drive pins to reduce point loads on the face.
- Quench containment as standard. External quenching of the seal is always an option.

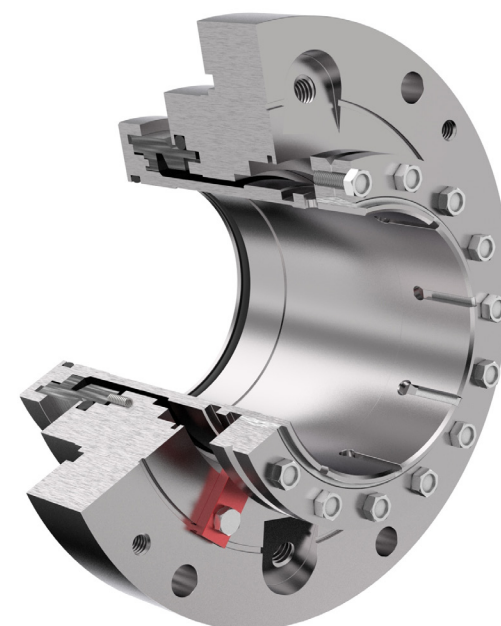

### Applications

- Acidic and chemically aggressive media.
- Mining.
- Ore processing.
- Pulp and Paper.

### Standard Materials

**Stationary:** SiC /TC **Rotary:** SiC /TC  
**Wetted Parts\*:** CD4MCuN , Alloy C-276, High Chrome Iron (standard)

**Face Materials:** Silicone Carbide, Tungsten Carbide

**Elastomers:** FFKM, NBR, EPDM, Viton, Aflas  
\*Other abrasion/corrosion-resistant materials available.

### Specifications

All operating range information is dependent on media, materials of construction, and support systems used. Please contact A.R. Thomson mechanical seal services department for more information.

**Temperatures:** 400°F (205°C)  
**Max Pressure:** 400 PSI (28 bar)  
\*For pressures in excess of 200 psi (14 bar) consult A.R. Thomson.  
**Slurry %, Max:** Solids 40% by weight  
**Max Shaft Speed:** < 25m/s (< 4900 fpm)  
**Max Slurry Particle:** MOHS 9 (scale 1 to 10)  
**Max Particle Size:** MOHS Hardness 6000 Micron

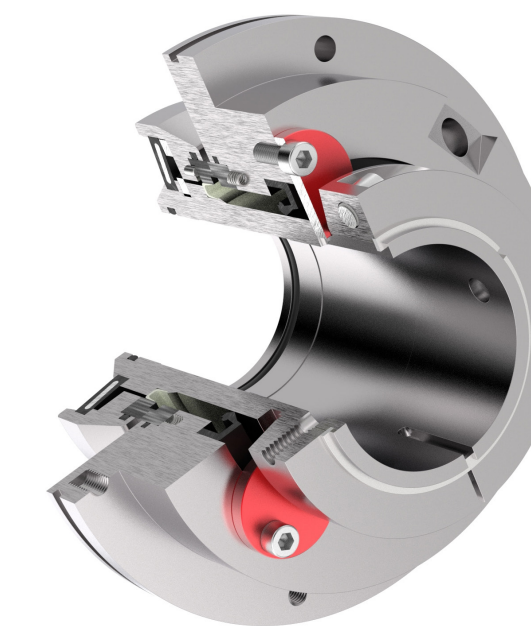

## TAC-640

Thomson TAC-640 heavy duty flush less slurry seal.

The Thomson TAC-640 is an engineered seal able to operate in 60% solids and greater with customizable gland and hardware to fit your specific application.

### Features / Benefits

- Up to 60% solids without flush or environmental controls required.
- Robust seal face, gland and component geometry.
- Abrasion and corrosion resistant metallurgy matching the pump wetted parts.
- Pre-set cartridge simplifying installation.
- Balanced design.

### Applications

- Heavy slurry applications (to 60%).
- Acidic and chemically aggressive media.
- Mining.
- Ore processing.
- Pulp and Paper.

### Specifications

All operating range information is dependent on media, materials of construction, and support systems used. Please contact A.R. Thomson mechanical seal services department for more information.

**Temperatures:** +180°F (+80°C) without quench  
+300°F (+150°C) with quench  
**Max Pressure:** 300 PSI (20 bar)  
\*For pressures in excess of 150 psi (10 bar) consult A.R. Thomson.  
**Max Shaft Speed:** < 25m/s (< 4920 fpm)  
**Slurry %, Max:** 60%

### Standard Materials

**Wetted Parts\*:** CD4MCuN  
**Face Materials:** Silicone Carbide, Tungsten Carbide  
**Elastomers:** FKM, NBR, EPDM  
\*Other abrasion/corrosion-resistant materials available.